

IGBT Discrete with Anti-Parallel Diode

电气特性/ Features and Benefits:

- 1200V 沟槽栅/场终止工艺
1200V trench gate/field termination process
- 低开关损耗
Low switching losses
- V_{cesat} 正温度系数
 V_{cesat} has a positive temperature coefficient

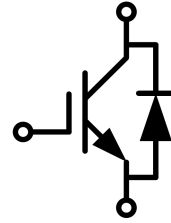

典型应用/ Applications:

- 储能逆变器
Energy storage inverter
- 不间断电源
Uninterruptible power supplies
- 光伏逆变器
Solar inverters

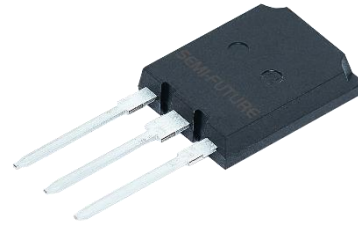

$V_{CES} = 1200V$, $I_{C\ nom} = 120A$ / $I_{CRM} = 360A$

关键性能和程序参数 / Key Performance and Package Parameters

Type	V_{CE}	I_C	V_{CESat} , $T_{vj}=25^\circ C$	T_{vjmax}	Package
SD120R12I7H	1200V	120A	1.83V	175°C	TO-247PLUS-3L

双极晶体管/IGBT

最大额定值 / Maximum Ratings

Parameter	Conditions	Symbol	Value	Unit
集电极-发射极电压 Collector-Emitter voltage	$T_{vj}=25^\circ C$	V_{CES}	1200	V
连续集电极直流电流 Continuous DC collector current	$T_C=100^\circ C$, $T_{vj\ max}=175^\circ C$	$I_{C\ nom}$	120	A
集电极重复峰值电流 Repetitive peak collector current	$t_p=1\ ms$	I_{CRM}	360	A
栅极-发射极电压 Gate emitter voltage	$t_p \leq 0.5\ \mu s$, $D < 0.001$	V_{GE}	± 20 ± 25	V
总功率损耗 Power dissipation	$T_C=25^\circ C$ $T_C=100^\circ C$	P_{tot}	1010 505	W

Changes of this product data sheet are reserved.
Edited by Semi-Future Technologies, Edition 1.0

在开关状态下温度 Temperature under switching conditions		$T_{vj\ op}$	-40...+175	°C
储存温度 Storage temperature		T_{stg}	-40...+150	°C

热特性 / Thermal Characteristics

Parameter	Conditions	Symbol	Value	Unit
IGBT 热阻, 结-壳 IGBT thermal resistance, junction - case		$R_{th(j-c)}$	0.12	K/W
二极管热阻, 结-壳 Diode thermal resistance, junction - case		$R_{th(j-c)}$	0.22	K/W

特征值 / Characteristic Values

Parameter	Conditions	Symbol	Value			Unit
			Min.	Typ.	Max.	
集电极-发射极饱和电压 Collector-Emitter saturation voltage	$V_{GE}=15V, I_C=120A$ $V_{GE}=15V, I_C=120A$ $V_{GE}=15V, I_C=120A$	$T_{vj}=25^\circ C$ $T_{vj}=150^\circ C$ $T_{vj}=175^\circ C$	V_{CEsat}	1.83 2.42 2.53	2.2	V
栅极-发射极阈值电压 Gate-Emitter threshold voltage	$I_C=2.34mA, V_{GE}=V_{CE}$	$T_{vj}=25^\circ C$	$V_{GE(th)}$	5.0 5.6	6.2	V
跨导 Transconductance	$V_{CE}=20V, I_C=120A$		G_{fs}	95		S
输入电容 Input capacitance			C_{ies}	17073		pF
输出电容 Output capacitance	$f=100kHz, V_{CE}=25V, V_{GE}=0V$	$T_{vj}=25^\circ C$	C_{oes}	402		pF
反向传输电容 Reverse transfer capacitance			C_{res}	126		pF
门极电荷 Gate charge	$I_C=120A, V_{GE}=15V,$ $V_{CE}=960V$	$T_{vj}=25^\circ C$	Q_G	1063		nC
集电极-发射极截止电流 Collector-emitter cut-off current	$V_{CE}=1200V, V_{GE}=0V$	$T_{vj}=25^\circ C$	I_{CES}		1	mA
栅极-发射极漏电流 Gate-emitter leakage current	$V_{CE}=0V, V_{GE}=20V$	$T_{vj}=25^\circ C$	I_{GES}		200	nA
开通延迟时间 Turn-on delay time	$I_C=120A, V_{CE}=600V$ $V_{GE}=\pm 15V, R_G=3.3\Omega$ (电感负载) / (inductive load)	$T_{vj}=25^\circ C$ $T_{vj}=175^\circ C$	$t_{d(on)}$	29 30		ns
上升时间 Rise time	$I_C=120A, V_{CE}=600V$ $V_{GE}=\pm 15V, R_G=3.3\Omega$ (电感负载) / (inductive load)	$T_{vj}=25^\circ C$ $T_{vj}=175^\circ C$	t_r	197 164		ns
关断延迟时间 Turn-off delay time	$I_C=120A, V_{CE}=600V$ $V_{GE}=\pm 15V, R_G=3.3\Omega$ (电感负载) / (inductive load)	$T_{vj}=25^\circ C$ $T_{vj}=175^\circ C$	$t_{d(off)}$	152 185		ns

下降时间 Fall time	$I_C=120A, V_{CE}=600V$ $V_{GE}=\pm 15V, R_G=3.3\Omega$ (电感负载) / (inductive load)	$T_{vj}=25^\circ C$ $T_{vj}=175^\circ C$	t_f		70 136		ns
开通损耗能量 (每脉冲) Turn-on energy loss per pulse	$I_C=120A, V_{CE}=600V$ $V_{GE}=\pm 15V, R_G=3.3\Omega$ $di/dt=600A/\mu s(T_{vj}=175^\circ C)$ (电感负载) / (inductive load)	$T_{vj}=25^\circ C$ $T_{vj}=175^\circ C$	E_{on}		17.49 26.06		mJ
关断损耗能量 (每脉冲) Turn-off energy loss per pulse	$I_C=120A, V_{CE}=600V$ $V_{GE}=\pm 15V, R_G=3.3\Omega$ $dv/dt=8400V/\mu s(T_{vj}=175^\circ C)$ (电感负载) / (inductive load)	$T_{vj}=25^\circ C$ $T_{vj}=175^\circ C$	E_{off}		4.11 6.55		mJ

二极管/Diode

最大额定值 / Maximum Ratings

Parameter	Conditions	Symbol	Value	Unit
反向重复峰值电压 Repetitive peak reverse voltage	$T_{vj}=25^\circ C$	V_{RRM}	1200	V
连续正向直流电流 Continuous DC forward current	$T_C=100^\circ C, T_{vj\ max}=175^\circ C$	I_F	120	A
正向重复峰值电流 Repetitive peak forward current	$t_p=1ms$	I_{FRM}	360	A

特征值 / Characteristic Values

Parameter	Conditions	Symbol	Value			Unit
			Min.	Typ.	Max.	
正向电压 Forward voltage	$I_F=120A, V_{GE}=0V$ $I_F=120A, V_{GE}=0V$ $I_F=120A, V_{GE}=0V$	$T_{vj}=25^\circ C$ $T_{vj}=150^\circ C$ $T_{vj}=175^\circ C$	V_F		2.06 1.91 1.87	2.5 V
反向恢复峰值电流 Peak reverse recovery current	$I_F=120A,$ $-di_F/dt=500A/\mu s(T_{vj}=175^\circ C)$ $V_R=600V, V_{GE}=-15V$	$T_{vj}=25^\circ C$ $T_{vj}=175^\circ C$	I_{RM}		26 62	A
反向恢复电荷 Reverse Recovered charge	$I_F=120A,$ $-di_F/dt=500A/\mu s(T_{vj}=175^\circ C)$ $V_R=600V, V_{GE}=-15V$	$T_{vj}=25^\circ C$ $T_{vj}=175^\circ C$	Q_{rr}		6.34 23.16	μC
反向恢复时间 Reverse Recovery Time	$I_F=120A,$ $-di_F/dt=500A/\mu s(T_{vj}=175^\circ C)$ $V_R=600V, V_{GE}=-15V$	$T_{vj}=25^\circ C$ $T_{vj}=175^\circ C$	t_{rr}		480 874	ns
反向恢复损耗 (每脉冲) Reverse recovered energy	$I_F=120A,$ $-di_F/dt=500A/\mu s(T_{vj}=175^\circ C)$ $V_R=600V, V_{GE}=-15V$	$T_{vj}=25^\circ C$ $T_{vj}=175^\circ C$	E_{rec}		2.40 8.74	mJ



图 1. 典型输出特性 ($T_{vj}=25^{\circ}\text{C}$)
Figure 1. Typical output characteristics ($T_{vj}=25^{\circ}\text{C}$)



图 2. 典型输出特性 ($T_{vj}=175^{\circ}\text{C}$)
Figure 2. Typical output characteristics ($T_{vj}=175^{\circ}\text{C}$)

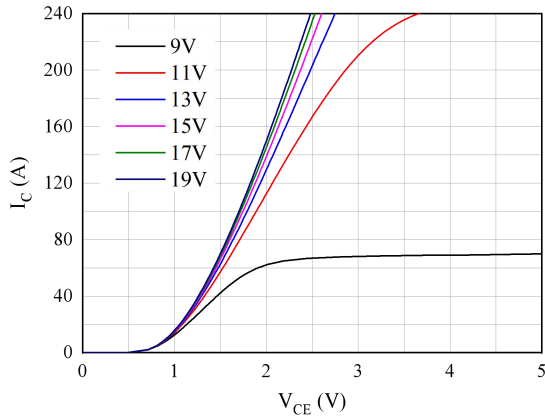

图 3. 典型输出特性 ($V_{GE}=15\text{V}$)
Figure 3. Typical output characteristics ($V_{GE}=15\text{V}$)

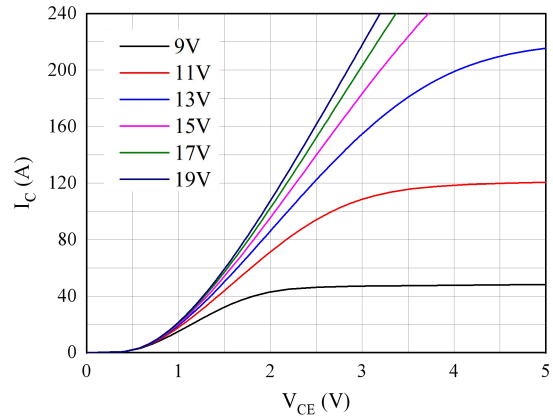

图 4. 典型传输特性 ($V_{CE}=20\text{V}$)
Figure 4. Typical transfer characteristic ($V_{CE}=20\text{V}$)

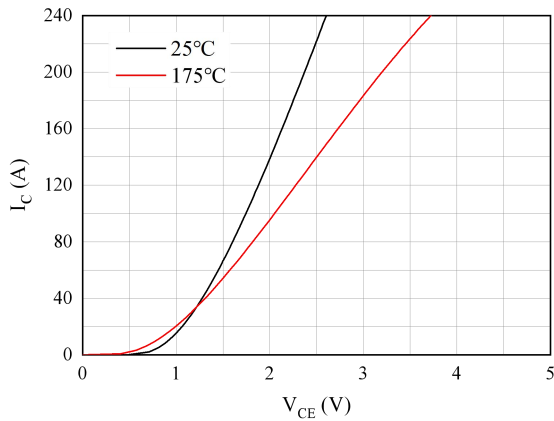

图 5. 正向偏压特性 二极管
Figure 5. Forward characteristic of Diode

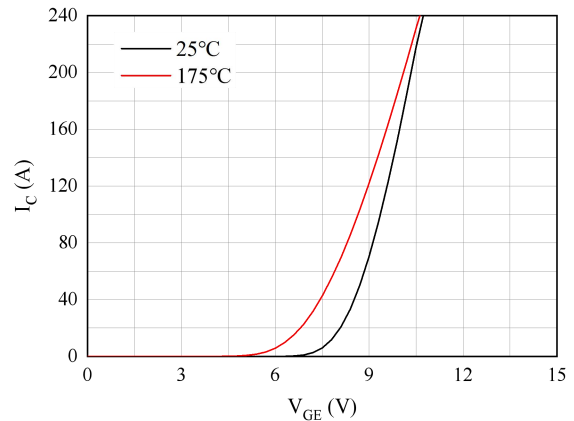

图 6. 电容特性
Figure 6. Capacitance characteristic

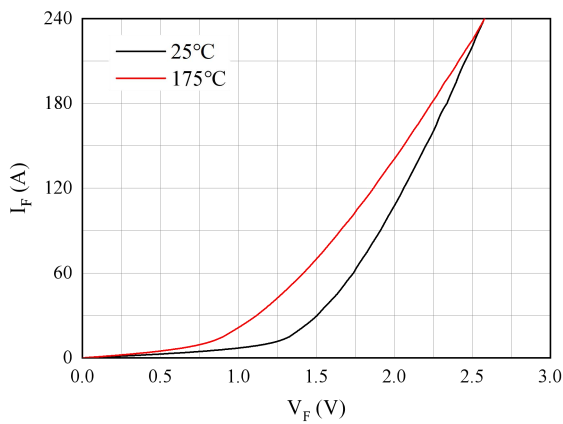

图 7. 瞬态热阻抗 IGBT
Figure 7. Transient thermal impedance IGBT,
 $Z_{thJC}=f(t)$

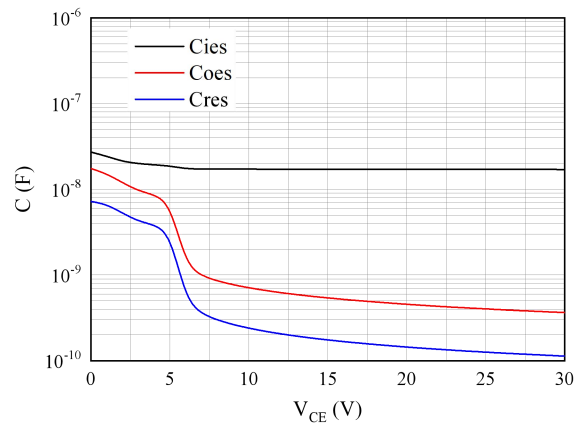

图 8. 瞬态热阻抗 FRD
Figure 8. Transient thermal impedance FRD,
 $Z_{thJC}=f(t)$

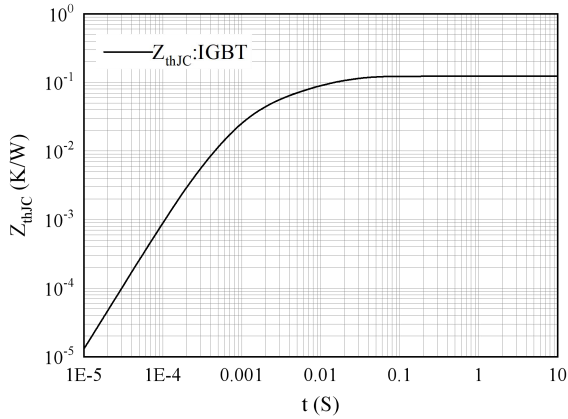

图 9. 开关损耗
Figure 9. Switching losses of IGBT
 $V_{GE}=\pm 15V, R_{gon}=3.3\Omega, R_{goff}=3.3\Omega, V_{CE}=600V$

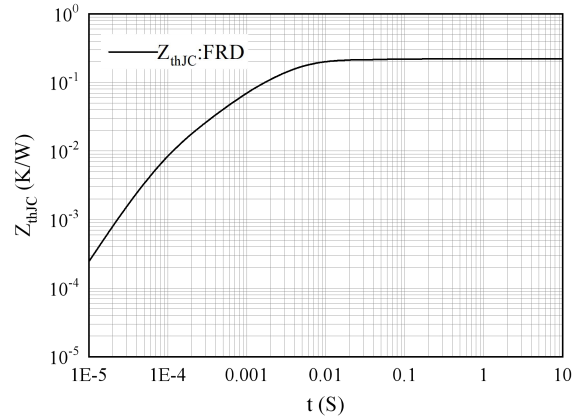

图 10. 开关损耗
Figure 10. Switching losses of IGBT
 $V_{GE}=\pm 15V, I_C=120A, V_{CE}=600V$

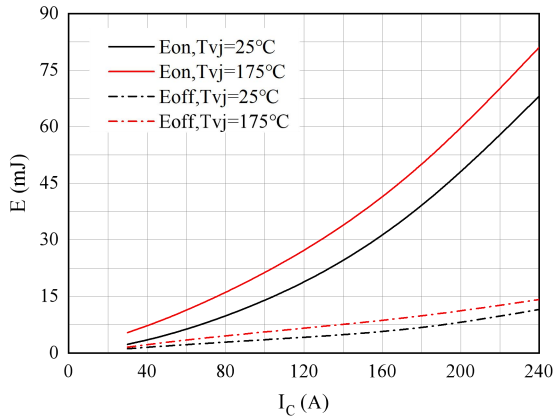

图 11. 开关损耗 二极管
Figure 11. Switching losses of Diode
 $R_{gon}=3.3\Omega, V_{CE}=600V$

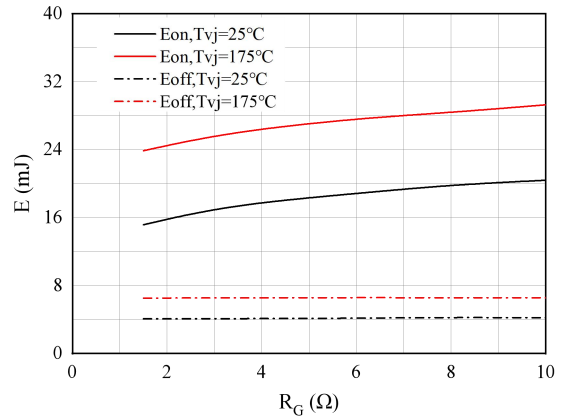

图 12. 开关损耗 二极管
Figure 12. Switching losses of Diode
 $I_F=120A, V_{CE}=600V$

接线图 / Circuit diagram

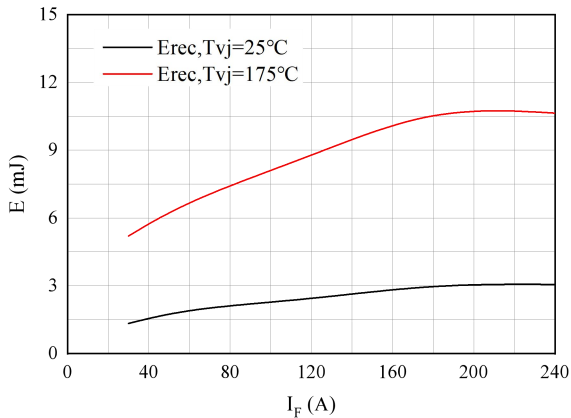

封装尺寸 / Package outlines

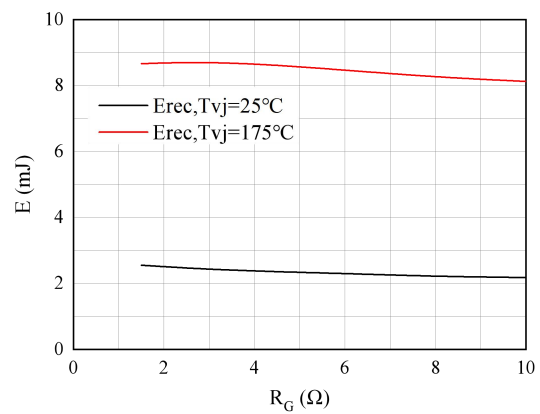
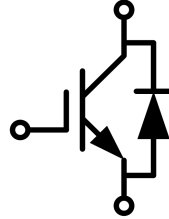
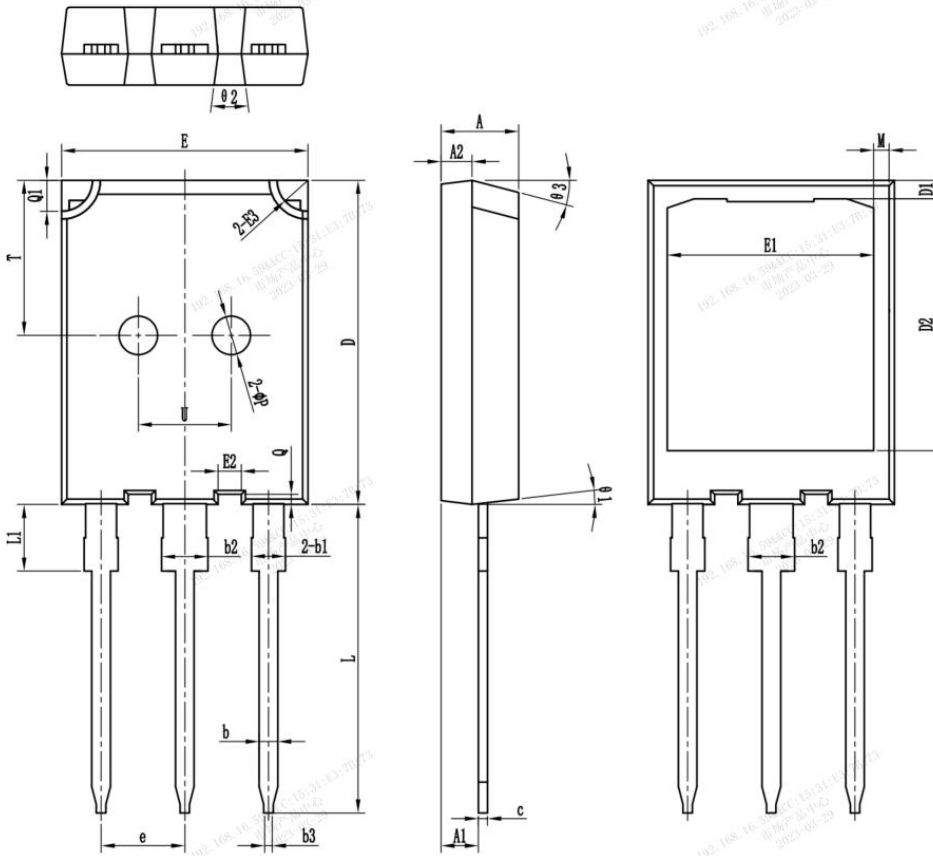

符号	单位:mm		
	MIN	NOM	MAX
*A	4.90	5.00	5.10
*A1	2.31	2.41	2.51
A2	1.90	2.00	2.10
*b	1.15	1.20	1.25
*b1	1.95	2.10	2.25
*b2	2.95	3.10	3.25
b3	0.45	0.60	0.75
*c	0.55	0.60	0.68
*D	20.90	21.00	21.10
D1	1.00	1.20	1.40
D2	16.05	16.35	16.65
*E	15.70	15.80	15.90
E1	13.10	13.30	13.50
E2	1.25	1.45	1.65
E3	1.80	2.00	2.20
*e	5.40	5.44	5.48
*L	19.80	19.92	20.10
*L1	-	-	4.30
M	0.5	0.7	0.9
ØP	2.30	2.50	2.70
Q	0.50	0.68	0.80
Q1	1.8	2.0	2.2
T	9.80	10.00	10.20
U	5.90	6.00	6.20
Ø1	5°	7°	9°
Ø2	13°	16°	19°
Ø3	13°	15°	17°

*为关键管控尺寸